

# Wacker Neuson Fourwheel drive dumper

## Technical Data

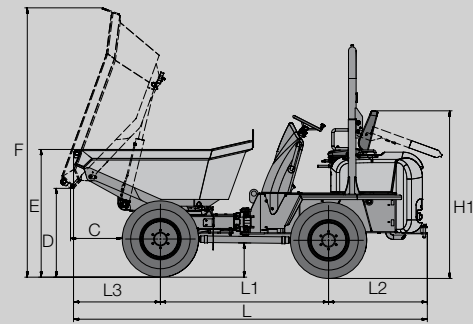

Front Tip

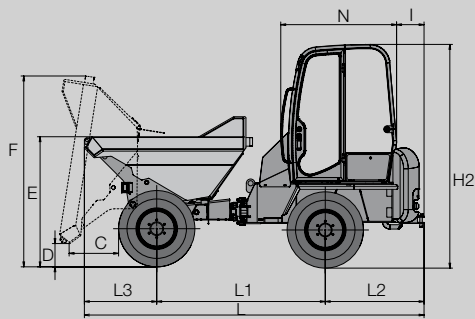
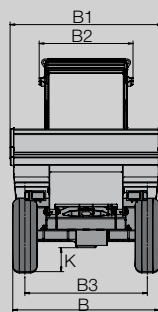

Swivel

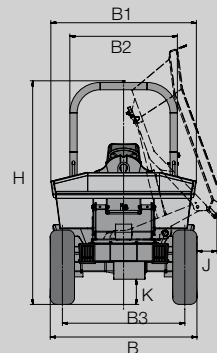

### DIMENSION

	3001 (Front Tip)	3001s (Swivel)
B	1785 mm	1785 mm
B1 / B2 / B3	1860 / 1310 / 1490 mm	1775 / 1310 / 1490 mm
C	570 mm	600 mm
D	260 mm	1020 mm
E	1475 mm	1475 mm
F	2220 mm	3125 mm
H	2670 mm	2670 mm
H1	1870 mm	1870 mm
H2*	2610* mm	-
I*	320* mm	-
J	-	245 mm
K	280 mm	280 mm
L	3980 mm	4140 mm
L1 / L2 / L3	1960 / 1160 / 860 mm	1960 / 1160 / 1020 mm
M	-	365 mm
N	1350* mm	-

\* nur für Kabine



**WACKER  
NEUSON**

 CAPACITY	3001 (Front Tip)	3001s (Swivel)
Max. safe load	3000 kg	3000 kg
Unladen weight	2450 kg	2550 kg
Skip struck	1500 l	1300 l
Skip heaped	1850 l	1750 l
Skip water level	1160 l	900 l
 ENGINE		
Make	YANMAR 3TNV88	YANMAR 3TNV88
Type	3-cyl, watercooled	3-cyl, watercooled
Output (Iso 3046/1)	25,2 kW (34,3 HP)	25,2 kW (34,3 HP)
Displacement	1642 cm <sup>3</sup>	1642 cm <sup>3</sup>
Revolution	2800 min <sup>-1</sup>	2800 min <sup>-1</sup>
Emission	ac. 97/68/EG, 3A	ac. 97/68/EG, 3A
 DRIVE CHARACTERISTICS		
Speed I / II	0–7 km/h / 0–22 km/h	0–7 km/h / 0–22 km/h
Steering angle	+/- 37°	+/- 37°
Oscillation	+/- 15°	+/- 15°
Turning radius outside	4000 mm	3950 mm
Gradeability	50 %	50 %
 TRANSMISSION		
Final Drive	automotive hydrostatic drive via dropbox to axle and wheels	
Steering	hydrostatic center-pivot steering	hydrostatic center-pivot steering
Tyres	11.50/80-15,3; Traction profile	11.50/80-15,3; Traction profile
Working brake	via foot pedal and wet multidisc in front axle	
Parking brake	wet multidisc brake operated by lever in front axle	
 HYDRAULIC SYSTEM		
Drive pump	axial piston pump	axial piston pump
flowrate	126 l/min	126 l/min
oper. pressure	360 bar	360 bar
Working pump	gear pump	gear pump
flowrate	45 l/min	45 l/min
oper. pressure	220 bar	220 bar
 TANK CAPACITY		
Diesel	40 l	40 l
Hydraulic	40 l	40 l
 ELECTRIC		
Voltage	12 V	12 V
Battery	88 Ah	88 Ah
Alternator	40 A	40 A
Starter	1,7 kW	1,7 kW
 NOISE EMISSION		
Noise Level LWA (acc. 2000/14/EC)	101 dB(A)	101 dB(A)

#### OPTIONAL EQUIPMENT

#### 3001 • 3001s

- Flashing Beacon
- Reversing Alarm
- Spare Wheel
- Biodegradeable hydraulic oil
- Awning for control stand and seat
- Road lighting kit
- Rear view mirror
- Turf tyres
- Trailer socket
- Chock
- Swifel skip
- Special paint 1 no RAL (for parts in yellow only)
- Special paint 1 RAL (for parts in yellow only)
- High restricted skip 2200mm

#### OPTIONAL EQUIPMENT

#### 3001 • 3001s

- Security 24 (1500h)
- Security 24 (2000h)
- Datatag